

LED lighting

Dimpacks 2009

DC dimmers for LED lighting. Versions available with internal or external power supplies

Analogue 0-10V & DMX control versions to be used with separate power supplies

DC output to feed external controller such as the Autofader

Screw terminals & or RJ 45 connectors For DMX. Special versions with RJ45 output connections for 3 or 4 channels light modules



With internal 4A, 6A, 8A & 10A 24V power supplies & 8A, 12A & 16A 12V power supplies
External power supplies 2-25A 12 or 24V versions available
Specials with any combination of circuit boards & power supplies



Circuit boards available with 0.7A, 2.5/3A & 5/8A per channel work with 12-24V supply. Analogue 0-10V or DMX control

4 Channel DMX
0.5/0.7A per channel
3A total

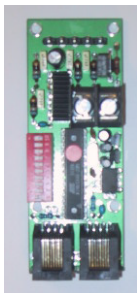

16 channel DMX0.5/0.7A
per channel 10A total

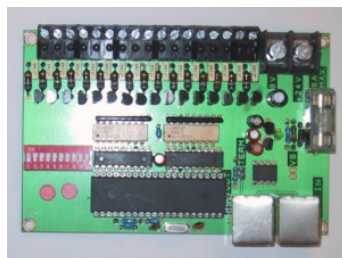

4 Channel DMX2.5/3A
per channel 10A total

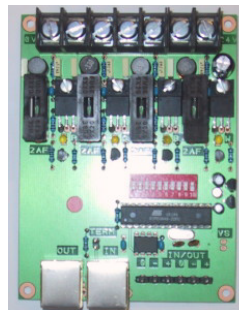

4 Channel DMX 5/8A
per channel 24A total

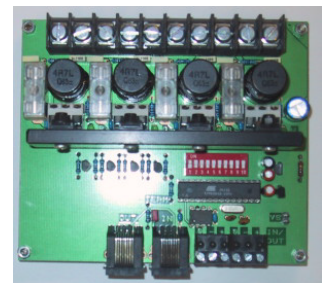

MALHAM LIGHTING DESIGN LTD
UNIT 12 THE METRO CENTRE
KANGLEY BRIDGE ROAD
LONDON SE26 5BW
TEL +44 (0) 208 676 7976 FAX +44 (0)208 676 7975
email sales@malham.co.uk

Dimpacks etc.

0-10V versions external PSU's Com negative

Part No.

D4-5AT 4 Channel Dimpack 5A/chan in case
D8-5AT 8 Channel Dimpack 5A/chan in case

0-10V versions internal PSU's 12 or 24V DC max 8A 24V, 16A 12V Com negative

D4-2AT-424 or 412 4A 4Channel 2A/chan in case
D4-2AT-6** 6A 4Channel 2A/chan in case
D4-2AT-8** 8A 4Channel 2A/chan in case

DMX versions external PSU's Common positive

D4-05XT 4 Channel 0.5A/chan PCB only Screw output terminals
D4-05XR RJ45 DMX connectors

All these below have screw terminals & RJ45 connectors for DMX in/out

D4-2XT 4 Channel 2A/chan PCB only. Screw output terminals
D16-05XT 16 Channel 0.5A/chan PCB only. Screw output terminals
D16-05XR 16 Channel 0.5A/chan PCB only. RJ45 output terminals
D4-8XT 4 Channel 8A/chan in case 25A maximum load

DMX versions internal PSU's 12 or 24V DC max 8A 24V, 16A 12V Common positive

D4-2XT-424 or -412 4A 4Channel 2A/chan in case
D4-2XT-6** 6A 4Channel 2A/chan in case
D4-2XT-8** 8A 4Channel 2A/chan in case
D16-05X*-6** 6A 16 Channel 0.5A/chan in case
D16-05X*-8** 8A 16 Channel 0.5A/chan in case

Multiple board versions available i.e. As below 3No 16chan boards in case with 8A 24V supply

* Part number explanation

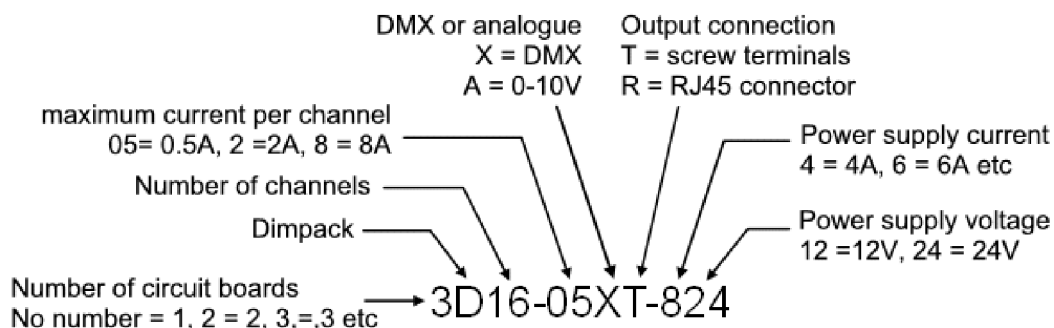

MALHAM LIGHTING DESIGN LTD

UNIT 12 THE METRO CENTRE

KANGLEY BRIDGE ROAD

LONDON SE26 5BW

TEL +44 (0) 208 676 7976 FAX +44 (0)208 676 7975

email sales@malham.co.uk

D16-05XT

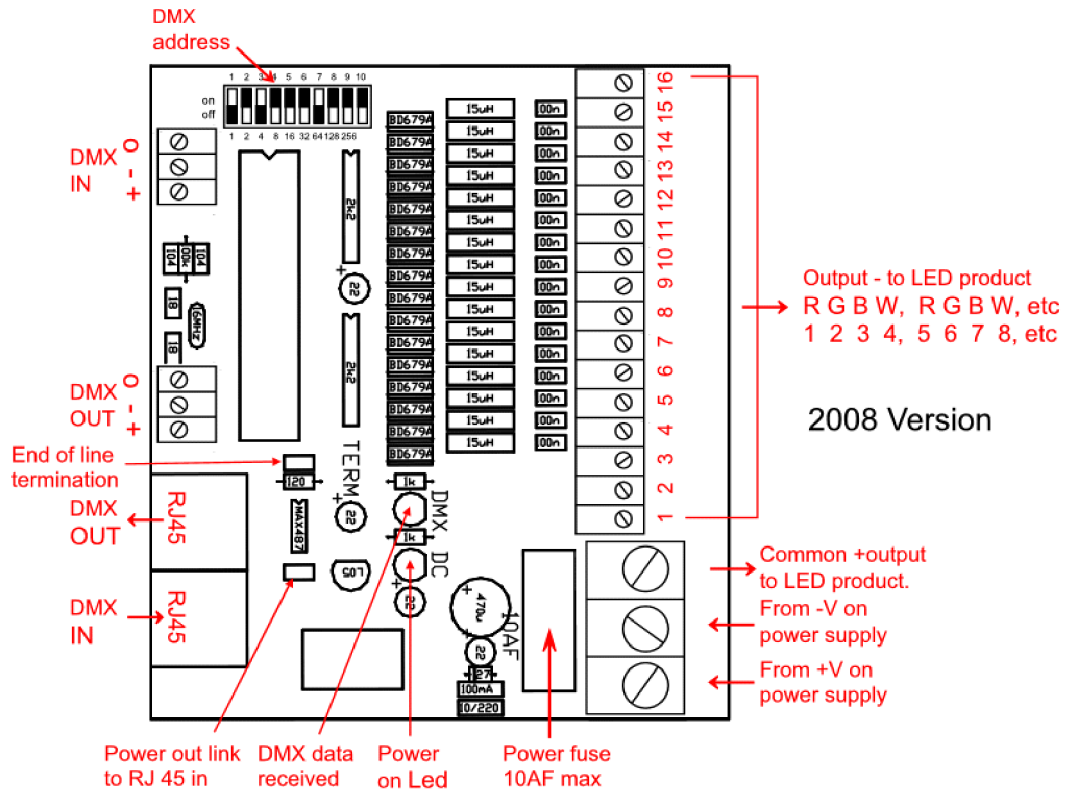

D16-05XR

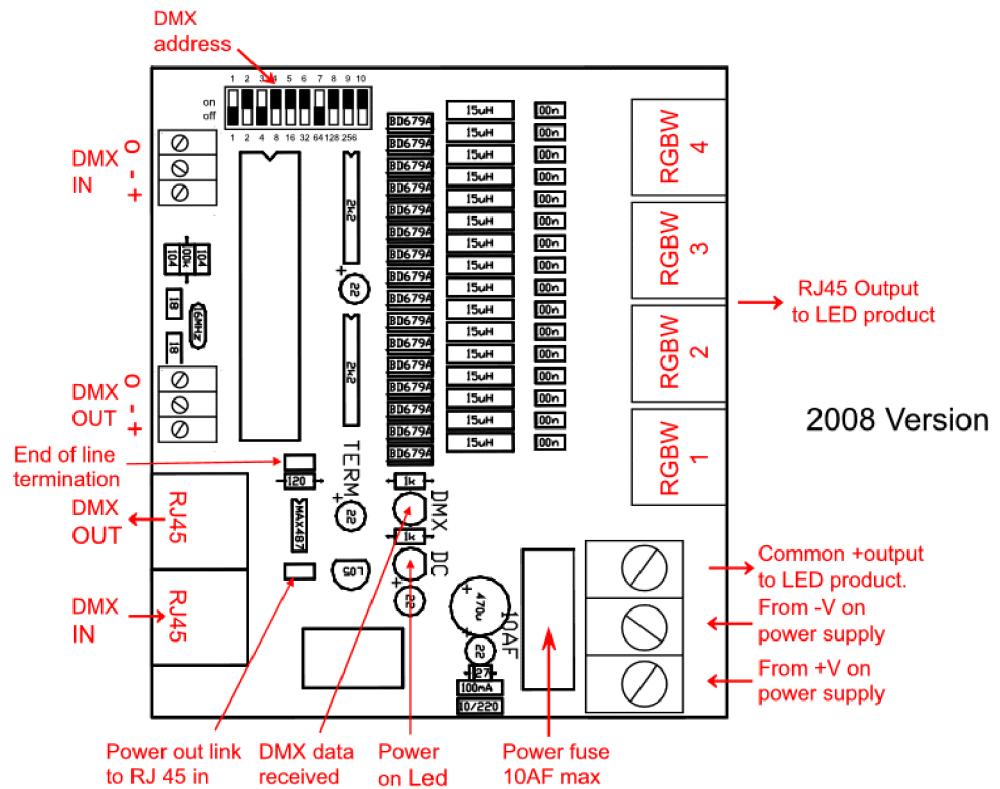

MALHAM LIGHTING DESIGN LTD

UNIT 12 THE METRO CENTRE

KANGLEY BRIDGE ROAD

LONDON SE26 5BW

TEL +44 (0) 208 676 7976 FAX +44 (0)208 676 7975

email sales@malham.co.uk

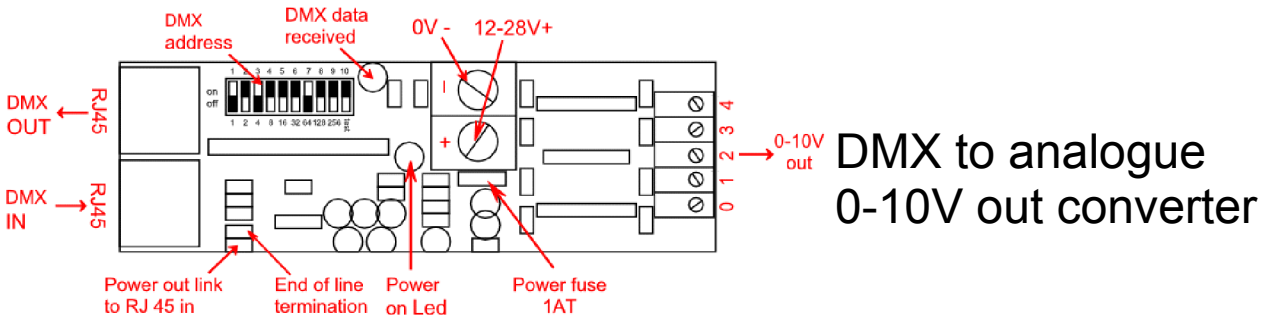
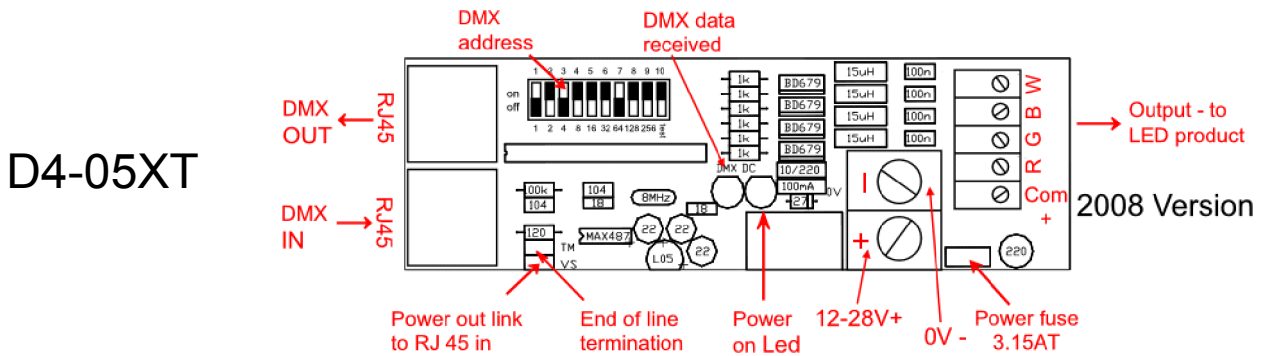
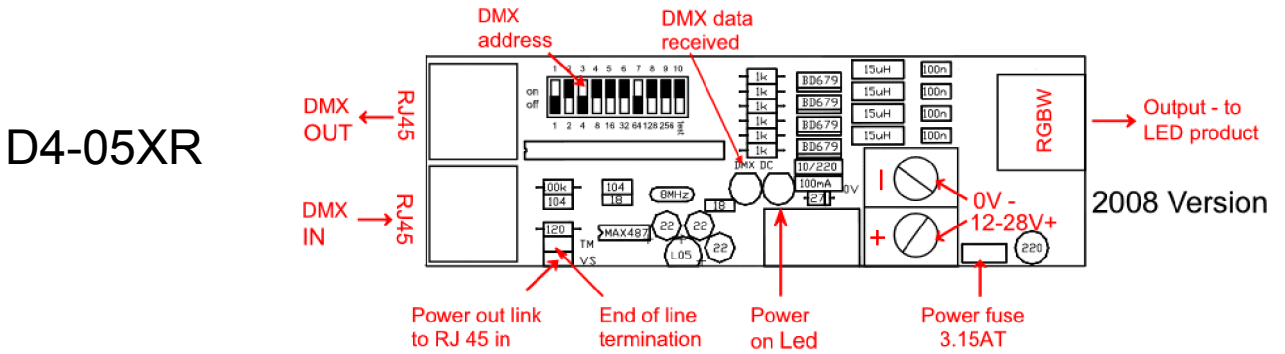
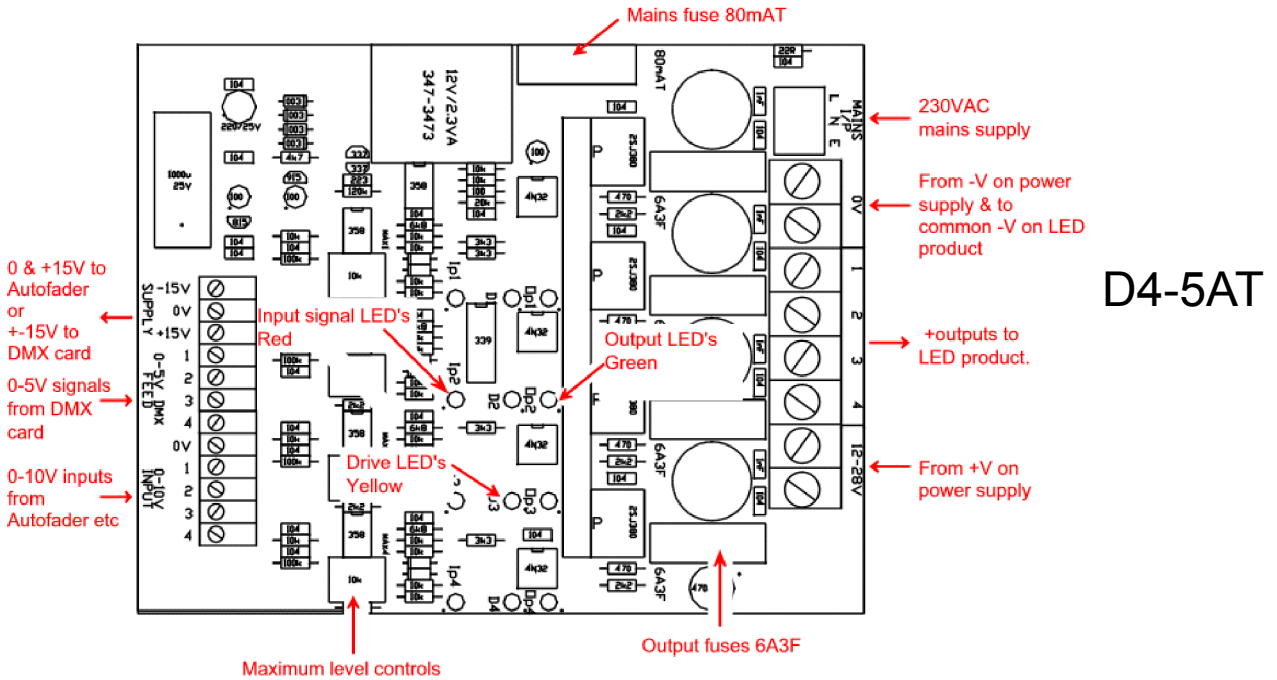

MALHAM LIGHTING DESIGN LTD
 UNIT 12 THE METRO CENTRE
 KANGLEY BRIDGE ROAD
 LONDON SE26 5BW
 TEL +44 (0) 208 676 7976 FAX +44 (0)208 676 7975
 email sales@malham.co.uk

DIP switch setting

DMX address

Switch 10 needs to be in the off position

DMX address is set by adding together the binary numbers
ie. as shown DMX address is; $1 + 4 + 64 = 69$

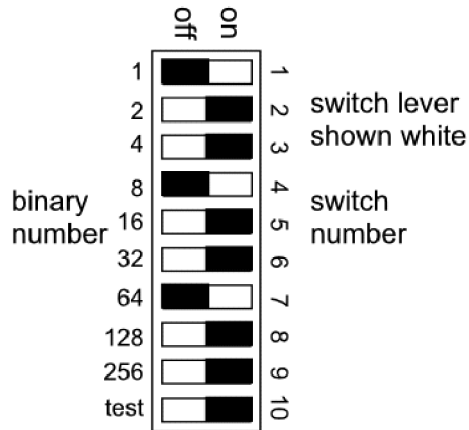

Test mode

Switch 10 in combination with the other switches are used for test purposes when setting up an installation

Switch numbers

- 1 Red
- 2 Green
- 3 Blue
- 4 White
- 5 Speed (see table)
- 6 Speed (see table)
- 7 RGB or RGBW (off) depending on setting of switch 9 or pretty colour sequence (on)
- 8 With switch 8 in the off position (static) switches 1-4 turn the channels 1-4 on & off. In the on position (fading) switches 1-4 when all off make the channels 1-4 fade between each other & when on only the selected switches fade up & down. If switch 7 is on (pattern) switches 1-4 have no effect
- 9 In the off position it only works the first 3 channels RGB. In the on position it works all 4 channels RGBW
- 10 In the off position it works from DMX. In the on position it works in TEST MODE

switch lever shown white

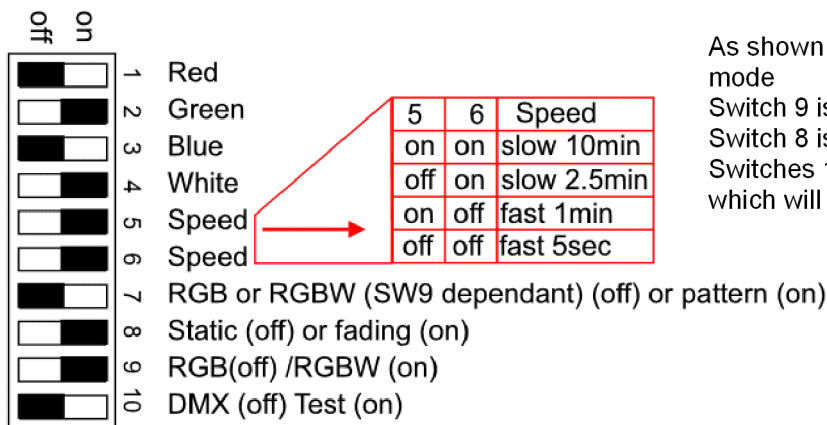

As shown switch 10 is on so it's in the test mode
Switch 9 is off so it's in 3 colour mode RGB
Switch 8 is off so it's in static colour mode
Switches 1 & 3 are on so red & blue are on which will give a magenta coloured mix



MALHAM LIGHTING DESIGN LTD
UNIT 12 THE METRO CENTRE
KANGLEY BRIDGE ROAD
LONDON SE26 5BW
TEL +44 (0) 208 676 7976 FAX +44 (0)208 676 7975
email sales@malham.co.uk

RJ 45 connections

T-568B Colour Code for RJ-45 Plug

There are two wiring standards for these cables, called "T-568A" and T-568B" They differ only in connection sequence, not in use of the various colours. The illustration shown is for T-568B, which is the one we use for link leads, easily available as patch leads in various lengths 1M, 2M, 3M, 5M, 10M etc.

Note that the odd pin numbers are always the white with stripe colour. Eight-conductor data cable CAT5, 5E, 6 etc contains 4 pairs of wires. Each pair consists of a solid (or predominantly) coloured wire and a white wire with a stripe of the same colour. The pairs are twisted together. To maintain reliability on DMX, you should not untwist them any more than necessary (like about 2-3 cm).

RJ 45 DMX inputs/outputs on dimpacks

White/orange = Data + Pin1
Solid orange = Data - Pin 2
White/brown = 0V Pin 7
Solid brown = 0V Pin 8
Power out (if jumper fitted as shown on PCB)
to autofader etc is available on
Pin 4 Blue +9V
Pin 5 White/blue +9V

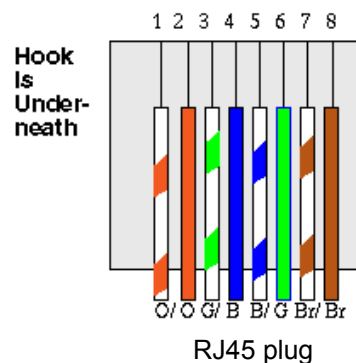

RJ 45 outputs on dimpacks to LED product

The solid colours are used as negative outputs,
striped as common positive

Solid orange = Red	White/orange = common red
Solid green = Green	White/green = common green
Solid blue = Blue	White/blue = common blue
Solid brown = White	White/brown = common white

All the commons are joined together on the circuit boards

Don't under any circumstances plug a DMX cable into a product output RJ45 connector as damage can occur in items on the DMX line



MALHAM LIGHTING DESIGN LTD
UNIT 12 THE METRO CENTRE
KANGLEY BRIDGE ROAD
LONDON SE26 5BW
TEL +44 (0) 208 676 7976 FAX +44 (0)208 676 7975
email sales@malham.co.uk

LED LIGHTING

Dimpacks types & dimensions.

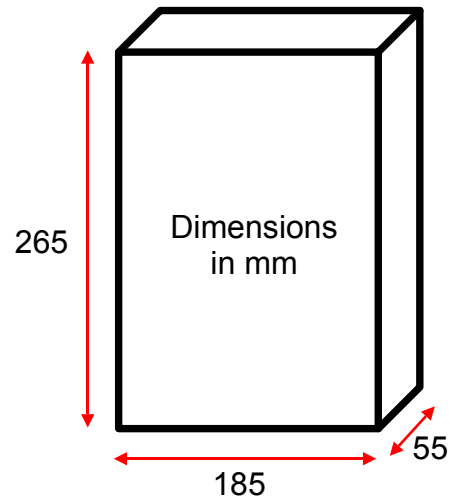

The enclosure above is used for 4 X 6/8A PCB with external 24V supplies above 10A & 12V supplies above 18A to a maximum of 24A for either voltage The total maximum load mustn't exceed 8A per channel.

This enclosure is also used for the 4 X 0.7A PCB with 12 & 42VA 12 or 24V supplies

The enclosure below is used for 4 X 2.5/3.3A PCB with internal 24V supplies up to 10A at 12V & 24V. The total maximum load mustn't exceed 3.3A per channel.

This enclosure is also used for the 16 X 0.7A PCB with up to 10A supply for either 12 or 24V supply. The maximum total load on the 16 channel board mustn't exceed 10A & 0.7A per channel

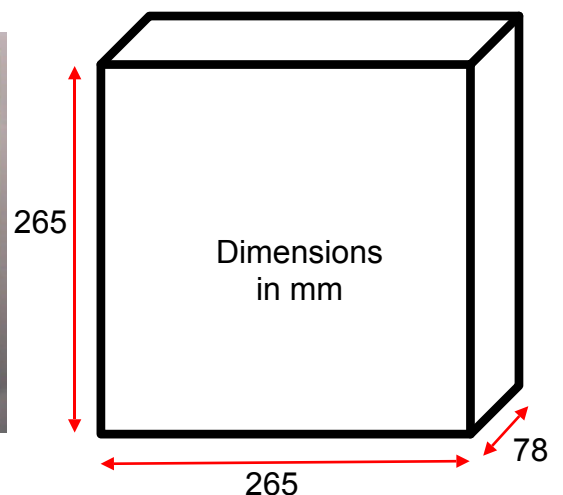

MALHAM LIGHTING DESIGN LTD

UNIT 12 THE METRO CENTRE

KANGLEY BRIDGE ROAD

LONDON SE26 5BW

TEL +44 (0) 208 676 7976 FAX +44 (0)208 676 7975

email sales@malham.co.uk